



# Table of contents

<b>1</b>	<b>Important product information</b>	<b>4</b>
1.1	Safety information	4
1.2	FCC information	4
1.3	Disposal instructions	5
<b>2</b>	<b>About this manual</b>	<b>6</b>
2.1	Digital document	6
2.2	Intended audience	6
2.3	Copyright notice	6
2.4	Trademarks	6
2.5	Notice of liability	6
2.6	Short information	7
<b>3</b>	<b>Product introduction</b>	<b>8</b>
3.1	Features and functions	8
<b>4</b>	<b>General installation procedures</b>	<b>10</b>
4.1	Unpacking	10
4.2	Parts included	10
4.3	Dimensions	12
4.4	Mounting and ventilation	13
4.5	Mains power connection	15
4.5.1	ghostPOWER via PoE	15
4.6	Mains operation and resulting temperature	17
<b>5</b>	<b>Installation</b>	<b>22</b>
5.1	Front panel	22
5.2	Rear panel	22
5.3	Control port	23
5.4	Audio connections	24
5.5	OMNEO/Dante/OCA network connection	25
<b>6</b>	<b>Configuration in SONICUE</b>	<b>27</b>
6.1	Updating the firmware	27
6.2	Web server	28
6.3	DSP and routing	30
6.4	TaskEngine	33
<b>7</b>	<b>Third party remote control</b>	<b>34</b>
<b>8</b>	<b>Technical data</b>	<b>35</b>
8.1	Output power	35
8.2	Amplifier	37
8.3	Digital signal processing	38
8.4	Connectivity	39
8.5	General	40

# 1 Important product information

## 1.1 Safety information

1. Read and keep these safety instructions. Follow all instructions and heed all warnings.
2. Download the latest version of the applicable installation manual from [www.boschsecurity.com](http://www.boschsecurity.com) for installation instructions.



### Information

Refer to the Installation Manual for instructions.

3. Follow all installation instructions and observe the following alert signs:



**Notice!** Containing additional information. Usually, not observing a notice does not result in damage to the equipment or personal injuries.



**Caution!** The equipment or the property can be damaged, or persons can be injured if the alert is not observed.



**Warning!** Risk of electric shock.

4. System installation and servicing by qualified personnel only, in accordance with applicable local codes. No user-serviceable parts inside.
5. System installation for emergency sound (except for call stations and call station extensions) in a Restricted Access Area only. Children may not get access to the system.
6. For rack-mounting of system devices, make sure that the equipment rack is of suitable quality to support the weight of the devices. Use caution when moving a rack to avoid injury from tip over.
7. The apparatus shall not be exposed to dripping or splashing and no objects filled with liquids, such as vases, shall be placed on the apparatus.
8. Mains powered equipment shall be connected to a mains power outlet socket with a protective earthing connection. An external, readily operable, mains plug or all-pole mains switch shall be installed.
9. The protective ground connection of an apparatus shall be connected to protective ground before the apparatus is connected to a power supply.
10. This unit has an autoranging input circuitry suitable for 100-240 Vac.
11. To prevent hearing damage do not listen at high volume levels for long periods.

## 1.2 FCC information

### FCC Supplier's Declaration of Conformity

F01U425387	IX60:8-US	8-channel DSP power amplifier, 6kW, US
F01U425388	IX60:4-US	4-channel DSP power amplifier, 6kW, US
F01U425389	IX30:8-US	8-channel DSP power amplifier, 3kW, US
F01U425390	IX30:4-US	4-channel DSP power amplifier, 3kW, US
F01U425391	IX15:4-US	4-channel DSP power amplifier, 1.5kW, US

**Compliance statement**

This device complies with part 15 of the FCC Rules. Operation is subject to the following two conditions: (1) This device may not cause harmful interference, and (2) this device must accept any interference received, including interference that may cause undesired operation.

**Responsible party**

Bosch Security Systems, LLC  
130 Perinton Parkway  
14450 Fairport, NY, USA  
[www.boschsecurity.us](http://www.boschsecurity.us)

Changes or modifications not expressly approved by the party responsible for compliance could void the user's authority to operate the equipment.

**Note:** This equipment has been tested and found to comply with the limits for a Class A digital device, pursuant to part 15 of the FCC Rules. These limits are designed to provide reasonable protection against harmful interference when the equipment is operated in a commercial environment. This equipment generates, uses, and can radiate radio frequency energy and, if not installed and used in accordance with the instruction manual, may cause harmful interference to radio communications. Operation of this equipment in a residential area is likely to cause harmful interference in which case the user will be required to correct the interference at his own expense.

**1.3**

**Disposal instructions**

**Old electrical and electronic equipment**

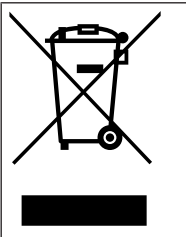
	<p>This product and/or battery must be disposed of separately from household waste. Dispose such equipment according to local laws and regulations, to allow their reuse and/or recycling. This will help in conserving resources, and in protecting human health and the environment.</p>
---	--

## 2 About this manual

The purpose of this manual is to provide information required for installing, configuring, operating and maintaining this product.

Read through this manual to familiarize yourself with the safety information, features, and applications before you use this product.

This is a professional product that should be installed, used and maintained by trained professionals only.

### 2.1 Digital document

This manual is available as a digital document in the Adobe Portable Document Format (PDF).

You can find information about Dynacord products on the product related information at [www.kling-freitag.com](http://www.kling-freitag.com).

### 2.2 Intended audience

This manual is intended for everyone who is authorized and professionally qualified to install and use this product.

### 2.3 Copyright notice

Unless otherwise indicated, this publication is the copyright of Dynacord. All rights are reserved.

### 2.4 Trademarks

Throughout this document trademark names may have been used. Rather than put a trademark symbol in every occurrence of a trademark name, Bosch Security Systems states that the names are used only in an editorial fashion and to the benefit of the trademark owner with no intention of infringement of the trademark.

### 2.5 Notice of liability

While every effort has been taken to ensure the accuracy of this document, neither Bosch Security Systems nor any of its official representatives shall have any liability to any person or entity with respect to any liability, loss or damage caused or alleged to be caused directly or indirectly by the information contained in this document.

Bosch Security Systems reserves the right to make changes to features and specifications at any time without prior notification in the interest of ongoing product development and improvement.

#### IT security disclaimer

In order to offer maximum compatibility with all networked audio devices and to allow for fast and easy setup and maintenance, our OMNEO-enabled products:

- do not verify the authenticity of any Dante or OCA controllers (or any other node) on the network

This means that these devices do not take any special precautions against malicious or accidental attacks via their network interfaces. Such attacks happen every day on the public internet. It is strongly recommended to set up the system in a safe, isolated network, meaning a network where all hardware components are known and physically owned and none of them is connected to the public internet.

#### Voice evacuation systems disclaimer

While capable of being used for announcements, this product has not been certified as component of voice evacuation systems according to EN54-16. Voice evacuation systems for life safety applications must not be designed and built using this product.

## 2.6 Short information

This document is applicable to these products:

CTN	Description
IX60:8	8-channel DSP power amplifier,6kW
IX60:4	4-channel DSP power amplifier,6kW
IX30:8	8-channel DSP power amplifier,3kW
IX30:4	4-channel DSP power amplifier,3kW
IX15:4	4-channel DSP power amplifier,1.5kW
IX60:8-US	8-channel DSP power amplifier,6kW,US
IX60:4-US	4-channel DSP power amplifier,6kW,US
IX30:8-US	8-channel DSP power amplifier,3kW,US
IX30:4-US	4-channel DSP power amplifier,3kW,US
IX15:4-US	4-channel DSP power amplifier,1.5kW,US

## 3 Product introduction

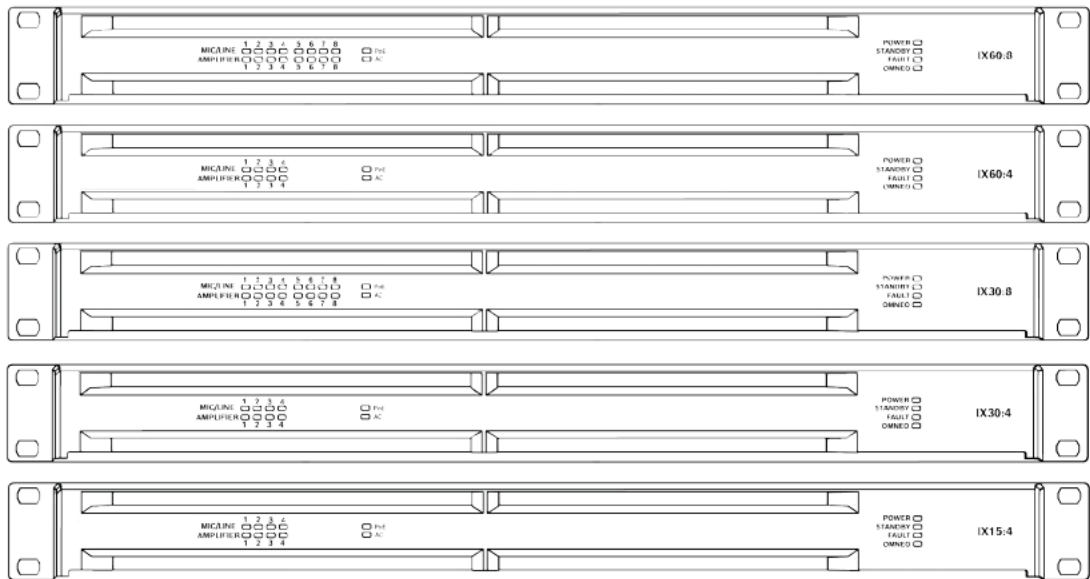

IX series power amplifiers are designed for use in professional audio installations like hospitality, sports venues, performing arts venues, conference and exhibition centers, houses of worship and many other installed applications that require high quality networked DSP power amplifiers. The series includes 8- and 4-channel networked DSP amplifiers with 6 to 1.5 kW total output power, capable to drive Hi-Z or Lo-Z loads with powerTANK technology.

The five models feature eight (8) Dante inputs, eight (8) Dante outputs and eight (8-channel models) or four (4-channel models) mic/line inputs that can be used as Dante break-in points.

The natively operating 96 kHz DSP features a fully equipped 16 x 16 (8-channel models) respectively 12 x 12 (4-channel models) matrix mixer, EQs, dynamics, Dynacord FX and FIR-Drive capability. All inputs feature pilot-tone detection, while the Dante outputs allow pilot tones up to 23 kHz and the amplifier outputs up to 30 kHz.

The IX series uses Dynacord's patented ecoRAIL technology for optimizing energy consumption. ghostPOWER via PoE maintains the entire DSP, the Dante network and all mic/line inputs active, independent of the mains power. The integrated MXE-style TaskEngine allows for system automation, scheduling, control, and integration to third party devices.

IX series is fully integrated in Dynacord's SONICUE Sound System Software and can be used as a SONICUE control server, for direct use with the WPN1 wall controller as well as TPC-1, iOS and Windows devices.

### 3.1 Features and functions

IX series amplifiers are multichannel networked amplifiers with mic/line inputs, Dante inputs and outputs and a DSP with speaker processing and full mixing capability.

	IX60:8	IX60:4	IX30:8	IX30:4	IX15:4
<b>Total power</b>	6000 W	6000 W	3000 W	3000 W	1500 W
<b>Amp channels</b>	8	4	8	4	4
<b>Mic/Line inputs</b>	8	4	8	4	4

	<b>IX60:8</b>	<b>IX60:4</b>	<b>IX30:8</b>	<b>IX30:4</b>	<b>IX15:4</b>
<b>Dante channels</b>	8 x 8	8 x 8	8 x 8	8 x 8	8 x 8
<b>Power all channels 4Ω</b>	8 x 600 W	4 x 1500 W	8 x 375 W	4 x 600 W	4 x 375 W
<b>Power all channels 8Ω/100V</b>	8 x 750 W	4 x 1200 W	8 x 375 W	4 x 750 W	4 x 375 W
<b>Max. output power (single channel)</b>	1000 W	1800 W	1000 W	1000 W	1000 W

- Lo-Z and Hi-Z drive capability per channel
- powerTANK for automatic power sharing
- 8 (4) mic/line inputs usable as Dante break-in with phantom power
- Powerful DSP with 16x16 (12x12) mixer, input processing and FIR-Drive
- 96 kHz native DSP operation
- 8x8 Dante with OCA/AES70 remote control
- ghostPOWER via PoE to maintain DSP, Dante network and mic/line inputs
- Comprehensive line monitoring and supervision
- MXE-style TaskEngine for system logic, automation, scheduling and integration
- High efficiency ecoRAIL technology for lower operating costs
- Configuration and operation in SONICUE Sound System Software

## 4 General installation procedures

Before starting the installation, ensure the following:

- You make use of manufacturer specified installation materials.
- No liquids can spill into or on the products.
- Installation is in a clean environment free of dust.
- The ventilation airflow of the 19" units is not obstructed.
- There is a mains power outlet of sufficient rating close to the intended location of the products.
- Sufficient free space and access at the rear of the 19" units for connectors and wiring.

### 4.1 Unpacking

The product should be unpacked and handled with care. If an item appears to be damaged, notify the shipper immediately. If any items are missing, notify your Dynacord representative.

The original packaging is the safest container in which to transport products and can also be used to return products for service, if necessary.

### 4.2 Parts included

Make sure that all parts are included and not damaged. If the packaging or any parts are damaged, contact your shipper. If any parts are missing, contact your Sales or Customer Service Representative.

**IX60:8 and IX30:8**

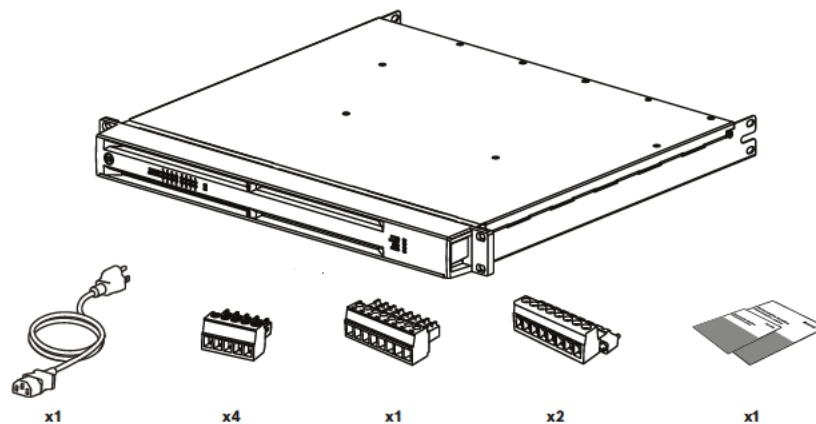

Quantity	Component
1	Power amplifier
1	Mains power cord
4	Euroblock input connector 5-pin <sup>1</sup>
1	Euroblock control port connector 8-pin <sup>2</sup>
2	Euroblock output connector 8-pin <sup>3</sup>
1	Quick installation guide
1	Safety information

<sup>1</sup> F.01U.434.765, MC1,5/5\_ST-3,81 or EC381V-05P

<sup>2</sup> F.01U.434.764, MC 1,5/8-ST-3,81, EC381V-08P

<sup>3</sup> F.01U.434.762, IC 2,5/8-STF-5,08

IX60:4

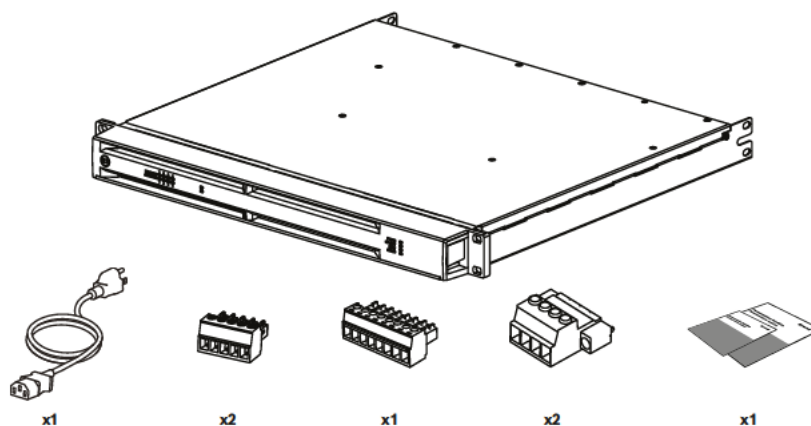

Quantity	Component
1	Power amplifier
1	Mains power cord
2	Euroblock input connector 5-pin <sup>1</sup>
1	Euroblock control port connector 8-pin <sup>2</sup>
2	Euroblock output connector 4-pin <sup>4</sup>
1	Quick installation guide
1	Safety information

<sup>1</sup> F.01U.434.765, MC1,5/5\_ST-3,81 or EC381V-05P

<sup>2</sup> F.01U.434.764, MC 1,5/8-ST-3,81, EC381V-08P

<sup>4</sup> F.01U.434763, IPC 5/4-STF-7,62

IX30:4 and IX15:4

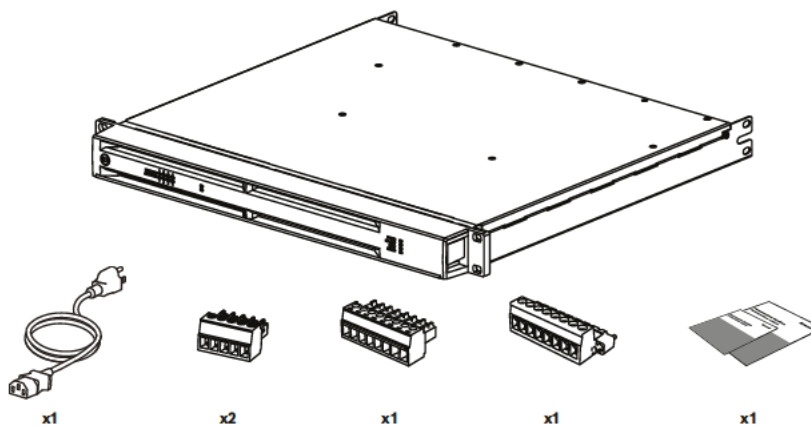

Quantity	Component
1	Power amplifier
1	Mains power cord

Quantity	Component
2	Euroblock input connector 5-pin <sup>1</sup>
1	Euroblock control port connector 8-pin <sup>2</sup>
1	Euroblock output connector 8-pin <sup>3</sup>
1	Quick installation guide
1	Safety information

<sup>1</sup> F.01U.434.765, MC1,5/5-ST-3,81 or EC381V-05P

<sup>2</sup> F.01U.434.764, MC 1,5/8-ST-3,81, EC381V-08P

<sup>3</sup> F.01U.434.762, IC 2,5/8-STF-5,08

### 4.3

### Dimensions

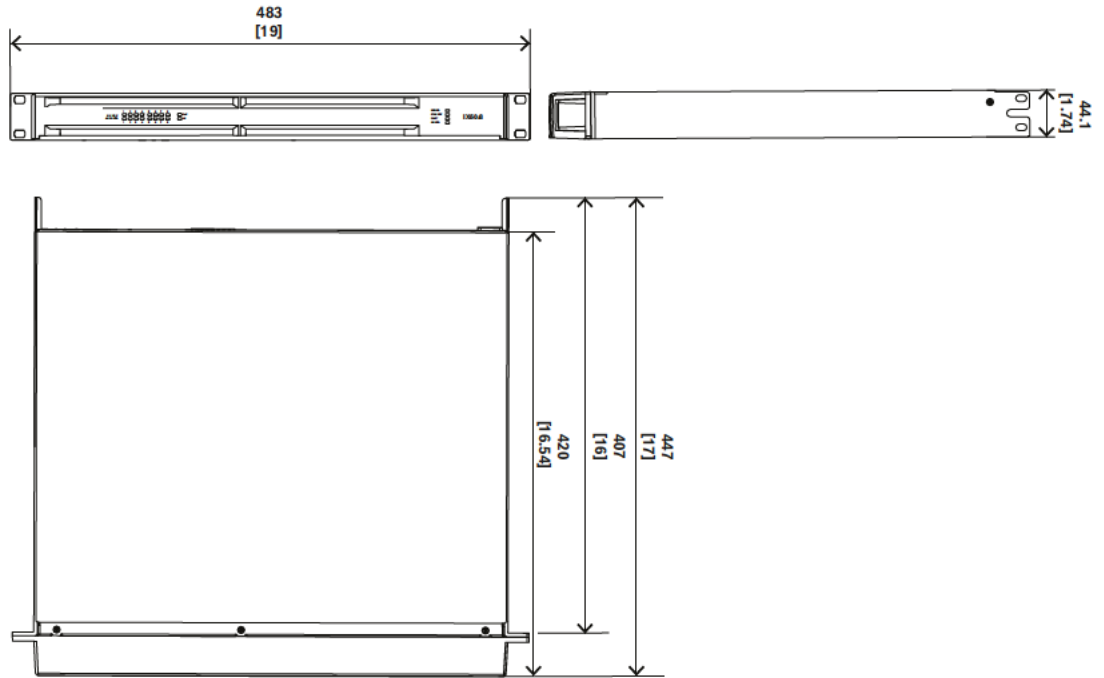

mm [in]

Figure 4.1: IX60:8 shown but dimensions are valid for all models

## 4.4 Mounting and ventilation

IX series amplifiers are designed for installation in common 19-inch racks.

- ▶ Attach the amplifier with four 20 mm screws and washers.

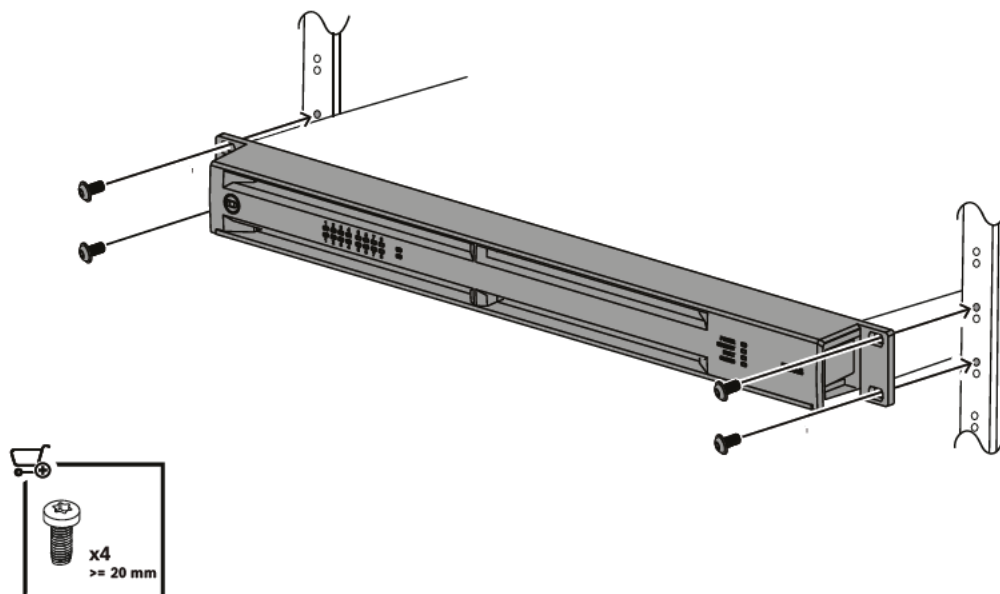

Additionally securing the amplifier by rack rails might be necessary in case you intend to transport the rack. Failure to do so may result in damage to the power amplifier as well as to the rack case.

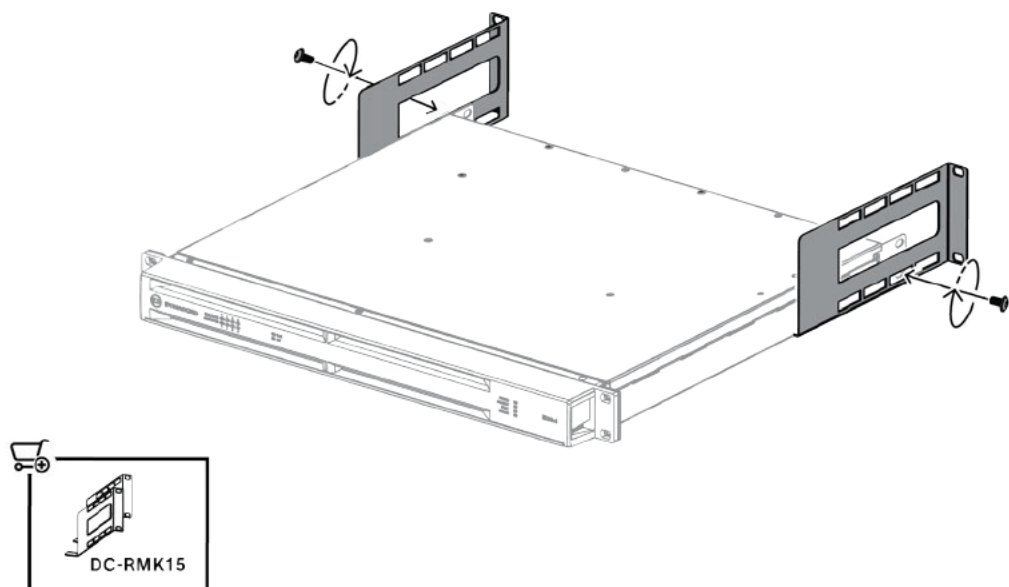
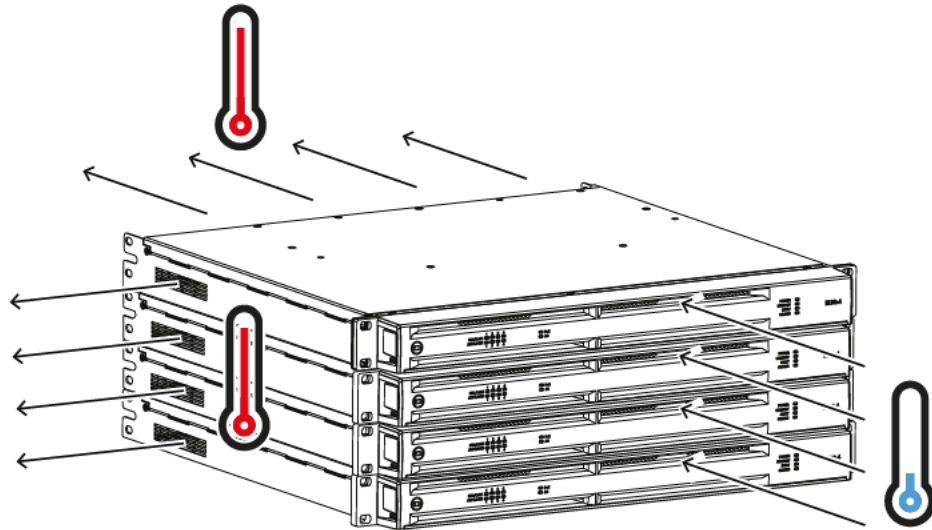

Figure 4.2: Mounting the amplifier using DC-RMK15 rack mount kit (not included)

DC-RMK15 rack mount kit allows you to mount one or two amplifiers with a single kit.

- ▶ Provide sufficient ventilation.



IX series amplifiers will often be installed in racks with other equipment, such as signal processors and other amplifiers. Consider that those devices accumulate heat within the rack space. An air duct of at least 30 cm between the rear panel of the IX series amplifiers and the inner wall of the cabinet or rack case is recommended. Make sure that the duct reaches up to the top ventilation louvers of the cabinets or the rack cases.

Since temperatures inside a rack can easily rise up to 40 °C during operation, it is mandatory to bear in mind the maximum allowable ambient temperature for all other appliances installed in the same cabinet or rack case.

Refer to *Mains operation and resulting temperature*, page 17 for information on power consumption and heat dissipation.



**Caution!**

Blocking/closing the power amp's ventilation louvers is not permissible. Without sufficient cooling/ventilation, the power amplifier may enter protect mode.

Keep ventilation louvers free from dust to ensure unhindered airflow.



**Notice!**

Do not use the power amplifier in direct sunlight or near heat sources, like heater blowers, stoves, or any other heat radiating devices.



**Notice!**

Do not use the power amplifiers in an environment where temperatures are below 5 °C (41 °F) or exceed +40 °C (104 °F).

For fixed amplifier installations in a device control room that incorporate a central air-cooling system or air conditioners, calculating the maximum heat emission may be necessary.



**Caution!**

Do not stack more than four amplifiers in a rack unit. Leave at least one rack unit space.

## 4.5 Mains power connection

The IX series products receive their power supply via the IEC MAINS inlet connector that will accept voltages from 100 to 240 volts AC, 50-60 Hz. Only use the included AC cable or AC cables approved for your country of use. During installation, always separate the device from the mains. Connect the device only to a mains network once the device is ready for operation.

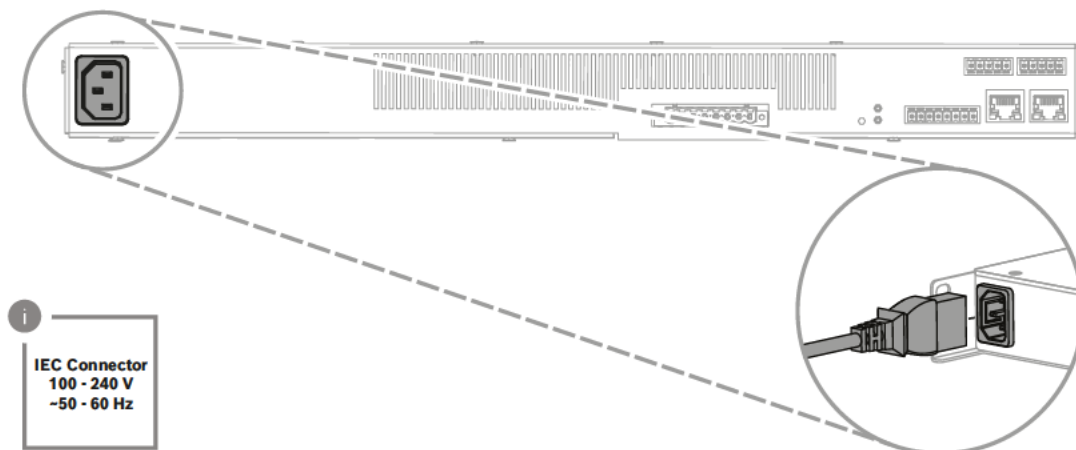

### Warning!

IX series is designed to tolerate mains power voltages +/-10% above/below the specified range. Mains power voltage outside that range can cause the amplifier to work at reduced performance, shut-off and in worst case even get damaged.

### 4.5.1 ghostPOWER via PoE

ghostPOWER, firstly introduced with Dynacord's IPX amplifiers, is a problem-solving technology to mitigate mains power outages.

Modern DSP amplifiers have boot-up time of 30 seconds and more, too long for mission critical systems that expect the sound system to be operational after maximum 10 seconds.

ghostPOWER was natively integrated into IPX amplifiers. The DSP and networking was kept alive for a minimum of 15 seconds without any additional measures. Thus, using UPSs (uninterruptable power supplies) for the network infrastructure allows creating a system in compliance with codes like NFPA70 or standards like UL 2572.

The IX series amplifiers use PoE (Power over Ethernet) to provide power for the DSP, networking and the mic/line inputs. If an IX amplifier is supplied with PoE, the DSP, networking and input section are by default supplied by PoE, while mains power serves as secondary power source.

#### Setting up PoE for ghostPOWER

IX series amplifiers require standard PoE according to IEEE802.3af (15.4 W) to utilize ghostPOWER. If PoE is supplied to IX amplifiers, it is the primary power source for the DSP, networking and input circuit. As long as PoE is present, the inputs, DSP and networking stay operational independent of mains power. This means all selected sources to the Dante network keep operational even when the amplifier is in stand-by mode, or has no mains power.

- ▶ Check the **PoE** and **AC** indicators on the front panel of the amplifier for proper PoE functionality.

Indicator status	General meaning	Meaning for DSP/Dante	Meaning for amp
PoE off	No PoE detected	Will stop working without mains power	n/a

Indicator status	General meaning	Meaning for DSP/Dante	Meaning for amp
PoE green	PoE in use	Will operate without mains power	n/a
PoE flashing red	PoE dropped and is not available as expected	PoE was available but has issues, such as power limitations and/or bad cabling. Will not work without mains power	n/a
PoE flashing red/green	PoE has dropped and has been reestablished recently	If flashing continues for more than 30 sec there is still an issue	n/a
PoE orange	Caution! PoE dropped in the last 24 hours	Should operate without mains power but a fail due to instable PoE supply cannot be ruled out	n/a

Indicator status	General meaning	Meaning for DSP/Dante	Meaning for amp
AC green	Mains AC power present	Working	Fully operational
AC orange	AC mains power in critical range	Working	Still working, but the voltage is either low or high, and close to the limits of regular operation, which can cause the voltage to collapse
AC red	AC mains power out of range (< 90 V, >280 V)	Working	Mains voltage is either too low or too high for regular power amplifier operation
AC off	No mains power available	Will only work if the PoE indicator is green or orange	No amplifier operation

To turn on PoE:

1. With no input in use, make the PoE connection.

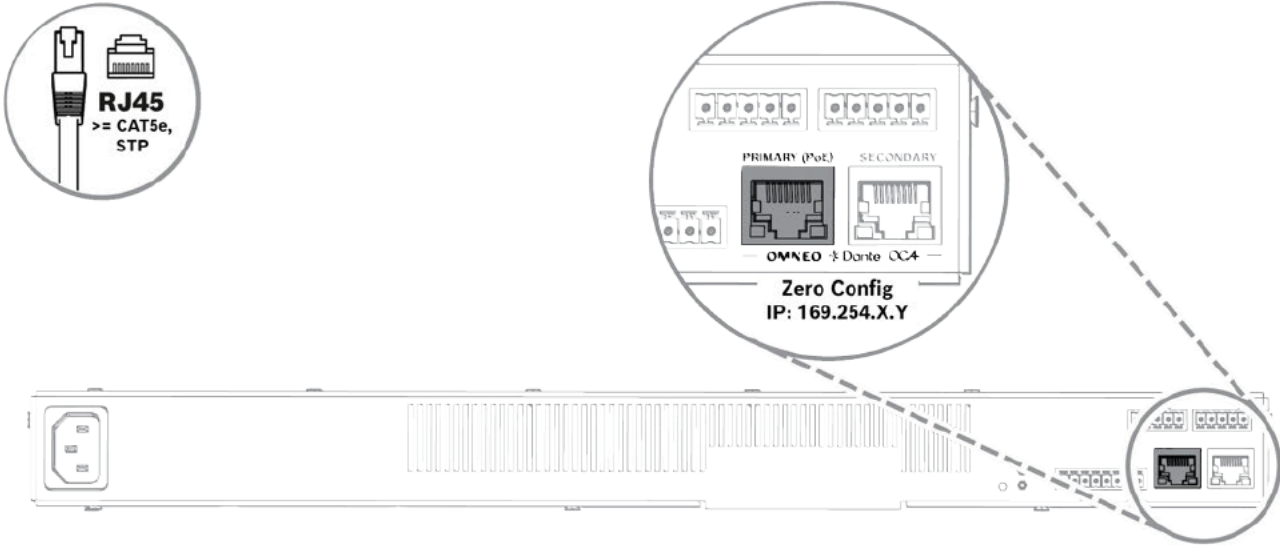

2. Check for a green **PoE** indicator.
3. Connect the mic/line inputs and apply phantom power if required.  
The **PoE** indicator shall maintain green.

If the **PoE** indicator starts flashing red, you run into a power limitation issue:

1. Check for proper PoE supply (no power limits and proper cabling).
2. Check the input cabling.



**Notice!**

A short in an input cable combined with activated phantom power could result in a current draw above the PoE limit.

## 4.6 Mains operation and resulting temperature

IX15:4

	$U_{\text{mains}}$ [V] <sup>1</sup>	$I_{\text{mains}}$ [A]	$P_{\text{mains}}$ [W] <sup>4</sup>	$P_{\text{out}}$ [W]	$P_{\text{d}}$ [W] <sup>3</sup>	BTU/hr <sup>2</sup>
Standby	230	0.3	11	0	11	38
ecoRAIL (idle)	230	0.4	24	≤1	23	79
1/8 of 375 W Pink Noise @ 8 Ω, (4-16 Ω mode)	230	1.3	309	188	121	412
1/8 of 375 W Pink Noise @ 4 Ω, (4-16 Ω mode)	230	1.6	360	188	172	586
1/8 of 375 W Pink Noise 70 V mode	230	1.3	291	188	104	355

	$U_{\text{mains}}$ [V] <sup>1</sup>	$I_{\text{mains}}$ [A]	$P_{\text{mains}}$ [W] <sup>4</sup>	$P_{\text{out}}$ [W]	$P_{\text{d}}$ [W] <sup>3</sup>	BTU/hr <sup>2</sup>
1/8 of 375 W 1 kHz sine 70 V mode	230	1.4	287	188	99	338
1/8 of 375 W Pink Noise 100 V mode	230	1.1	261	188	73	249
1/8 of 375 W 1 kHz sine 100 V mode	230	1.3	256	188	68	232

<sup>1</sup>Conversion factors for mains current 100 V = 2.3, 120 V = 1.9, 240 V = 0.96

<sup>2</sup>1 BTU = 1055.06 J = 1055.06 Ws

<sup>3</sup>Power dissipation

<sup>4</sup>All powers measured without PoE provided. With PoE the mains power will drop, but device power loss will remain the same.

#### IX30:4

	$U_{\text{mains}}$ [V] <sup>1</sup>	$I_{\text{mains}}$ [A]	$P_{\text{mains}}$ [W] <sup>4</sup>	$P_{\text{out}}$ [W]	$P_{\text{d}}$ [W] <sup>3</sup>	BTU/hr <sup>2</sup>
Standby	230	0.3	11	0	11	37
ecoRAIL (idle)	230	0.4	24	≤1	23	78
1/8 of 750 W Pink Noise @ 8 Ω, (4-16 Ω mode)	230	2.4	544	375	169	577
1/8 of 600 W Pink Noise @ 4 Ω, (4-16 Ω mode)	230	2.1	482	300	172	621
1/8 of 750 W Pink Noise 70 V mode	230	2.2	561	375	186	635
1/8 of 750 W 1 kHz sine 70 V mode	230	2.7	591	375	216	737
1/8 of 750 W Pink Noise 100 V mode	230	2.2	511	375	136	464
1/8 of 750 W 1 kHz sine 100 V mode	230	2.4	524	375	149	508

<sup>1</sup>Conversion factors for mains current 100 V = 2.3, 120 V = 1.9, 240 V = 0.96

<sup>2</sup>1 BTU = 1055.06 J = 1055.06 Ws

<sup>3</sup>Power dissipation

<sup>4</sup>All powers measured without PoE provided. With PoE the mains power will drop, but device power loss will remain the same.

### IX30:8

	$U_{\text{mains}}$ [V] <sup>1</sup>	$I_{\text{mains}}$ [A]	$P_{\text{mains}}$ [W] <sup>4</sup>	$P_{\text{out}}$ [W]	$P_{\text{d}}$ [W] <sup>3</sup>	BTU/hr <sup>2</sup>
Standby	230	0.3	14	0	14	48
ecoRAIL (idle)	230	0.4	37	≤1	36	122
1/8 of 375 W Pink Noise @ 8 Ω, (4-16 Ω mode)	230	2.4	553	375	178	607
1/8 of 375 W Pink Noise @ 4 Ω, (4-16 Ω mode)	230	2.8	634	375	259	884
1/8 of 375 W Pink Noise 70 V mode	230	2.3	548	375	173	590
1/8 of 375 W 1 kHz sine 70 V mode	230	2.5	551	375	176	601
1/8 of 375 W Pink Noise 100 V mode	230	2.4	537	375	162	553
1/8 of 375 W 1 kHz sine 100 V mode	230	2.4	517	375	142	485

<sup>1</sup>Conversion factors for mains current 100 V = 2.3, 120 V = 1.9, 240 V = 0.96

<sup>2</sup>1 BTU = 1055.06 J = 1055.06 Ws

<sup>3</sup>Power dissipation

<sup>4</sup>All powers measured without PoE provided. With PoE the mains power will drop, but device power loss will remain the same.

### IX60:4

	$U_{\text{mains}}$ [V] <sup>1</sup>	$I_{\text{mains}}$ [A]	$P_{\text{mains}}$ [W] <sup>4</sup>	$P_{\text{out}}$ [W]	$P_{\text{d}}$ [W] <sup>3</sup>	BTU/hr <sup>2</sup>
Standby	230	0.3	13	0	13	42
ecoRAIL (idle)	230	0.4	33	≤1	32	109
1/8 of 1200 W Pink Noise @ 8 Ω, (Lo-Z mode)	230	4.3	981	600	381	1300

	$U_{\text{mains}}$ [V] <sup>1</sup>	$I_{\text{mains}}$ [A]	$P_{\text{mains}}$ [W] <sup>4</sup>	$P_{\text{out}}$ [W]	$P_{\text{d}}$ [W] <sup>3</sup>	BTU/hr <sup>2</sup>
1/8 of 1500 W Pink Noise @ 4 $\Omega$ , (Lo-Z mode)	230	5.0	1158	750	408	1392
1/8 of 1500 W Pink Noise 70 V mode	230	5.4	1247	750	497	1696
1/8 of 1500 W 1 kHz sine 70 V mode	230	5.2	1158	750	408	1392
1/8 of 1500 W Pink Noise 100 V mode	230	4.5	1034	750	284	969
1/8 of 1500 W 1 kHz sine 100 V mode	230	4.6	1022	750	272	928

<sup>1</sup>Conversion factors for mains current 100 V = 2.3, 120 V = 1.9, 240 V = 0.96

<sup>2</sup>1 BTU = 1055.06 J = 1055.06 Ws

<sup>3</sup>Power dissipation

<sup>4</sup>All powers measured without PoE provided. With PoE the mains power will drop, but device power loss will remain the same.

#### IX60:8

	$U_{\text{mains}}$ [V] <sup>1</sup>	$I_{\text{mains}}$ [A]	$P_{\text{mains}}$ [W] <sup>4</sup>	$P_{\text{out}}$ [W]	$P_{\text{d}}$ [W] <sup>3</sup>	BTU/hr <sup>2</sup>
Standby	230	0.2	15	0	15	50
ecoRAIL (idle)	230	0.4	38	≤1	37	126
1/8 of 750 W Pink Noise @ 8 $\Omega$ , (4-16 $\Omega$ mode)	230	4.7	1085	750	335	1143
1/8 of 600 W Pink Noise @ 4 $\Omega$ , (4-16 $\Omega$ mode)	230	4.5	1029	600	429	1463
1/8 of 750 W Pink Noise 70 V mode	230	4.8	1099	750	349	1190
1/8 of 750 W 1 kHz sine 70 V mode	230	5.4	1207	750	457	1559

	$U_{\text{mains}}$ [V] <sup>1</sup>	$I_{\text{mains}}$ [A]	$P_{\text{mains}}$ [W] <sup>4</sup>	$P_{\text{out}}$ [W]	$P_{\text{d}}$ [W] <sup>3</sup>	BTU/hr <sup>2</sup>
1/8 of 750 W Pink Noise 100 V mode	230	4.5	1037	750	287	979
1/8 of 750 W 1 kHz sine 100 V mode	230	4.7	1066	750	316	1078

<sup>1</sup>Conversion factors for mains current 100 V = 2.3, 120 V = 1.9, 240 V = 0.96

<sup>2</sup>1 BTU = 1055.06 J = 1055.06 Ws

<sup>3</sup>Power dissipation

<sup>4</sup>All powers measured without PoE provided. With PoE the mains power will drop, but device power loss will remain the same.

## 5 Installation

### 5.1 Front panel

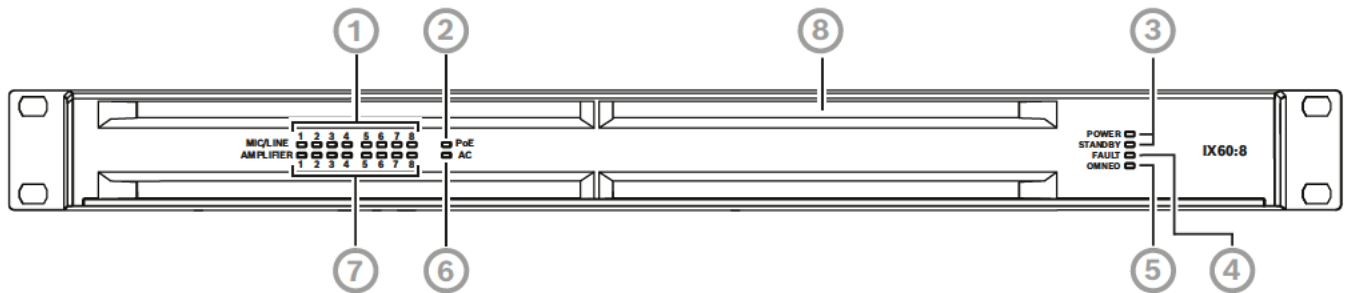
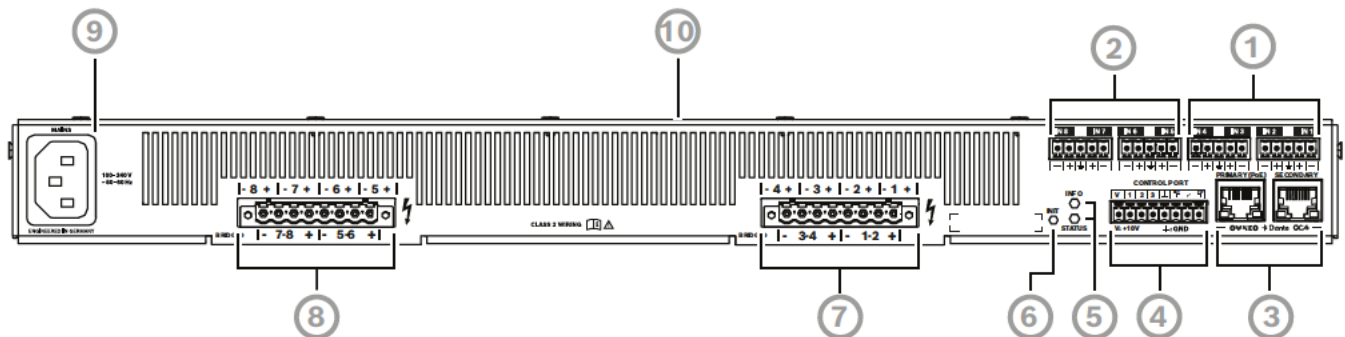

**Figure 5.1:** IX60:8 shown but description is valid for all models. Only the number of inputs and channels varies.

1. Input metering Mic/Line inputs
2. PoE indication
3. Power/Standby status
4. Fault indication
5. OMNEO network active
6. AC status
7. Amplifier channel output metering
8. Air intake

### 5.2 Rear panel

All models except IX60:4



1. Mic/Line input channels 1-4
  2. Mic/Line input channels 5-8\*
  3. OMNEO/Dante/OCA primary (PoE) and secondary network ports
  4. Control ports (GPIO)
  5. LED for INFO and STATUS
  6. Reset button
  7. Output connectors channels 1-4
  8. Output connectors channels 5-8\*
  9. Mains power connector
  10. Air outlet
- \*Only IX60:8 and IX30:8

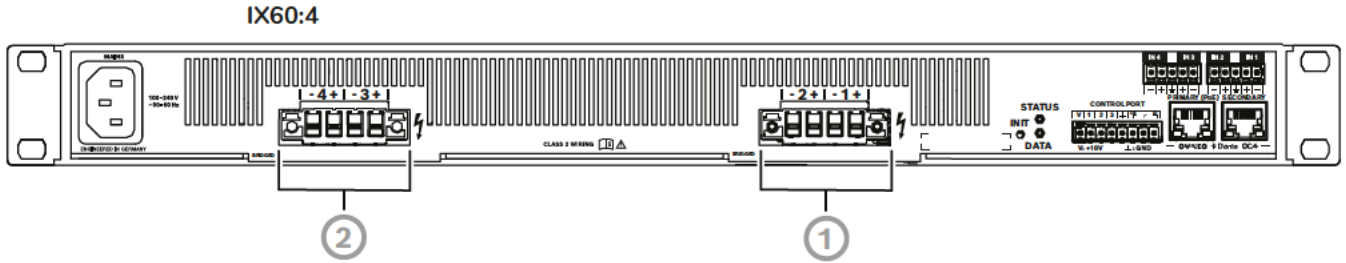

1. Output connectors channels 1 & 2
2. Output connectors channels 3 & 4

### 5.3

### Control port

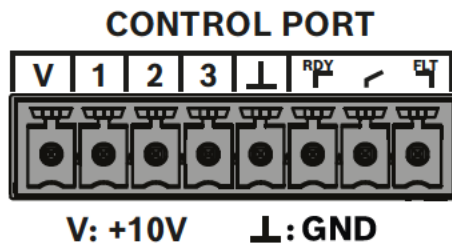

The control port features:

- three GPIOs (general purpose inputs & outputs)
- ready/fault contacts
- ground/+10 V reference pins
- 8-pin Euroblock-type connector

The three GPIOs are configurable for either control inputs or control outputs:

- Control inputs change device and system parameters, such as channel mute, preset selection, and others.
- Control outputs send parameter and status indication to external devices.

The other ports are potential-free relay toggle contacts for **READY** or **FAULT** indication.

The GPIO port configuration is done in SONICUE Sound System Software.

#### Ports and operating modes

<b>Analog Input Range</b>	0 V to +13 V, >100 kΩ input resistance
<b>Digital Input Limits</b>	ON: <1.5 V OFF: >2.0 V, internal Pull Up (10 V/10 kΩ)
<b>Digital Outputs</b>	ON: Output switched to GND, max. 200 mA OFF: Open Collector (>100 kΩ to GND)
<b>Reference Voltage Output</b>	+10 V, max. 200 mA, supervised, short circuit protected

## 5.4 Audio connections

### Input connections

The audio input connectors for microphone or line signals are 5-pin Euroblock-type. The pinouts are labeled on the rear of the device. It is highly recommended to use a balanced cabling configuration whenever possible. Using unbalanced cabling can result in poor audio quality and shall only be used on very short cable length.

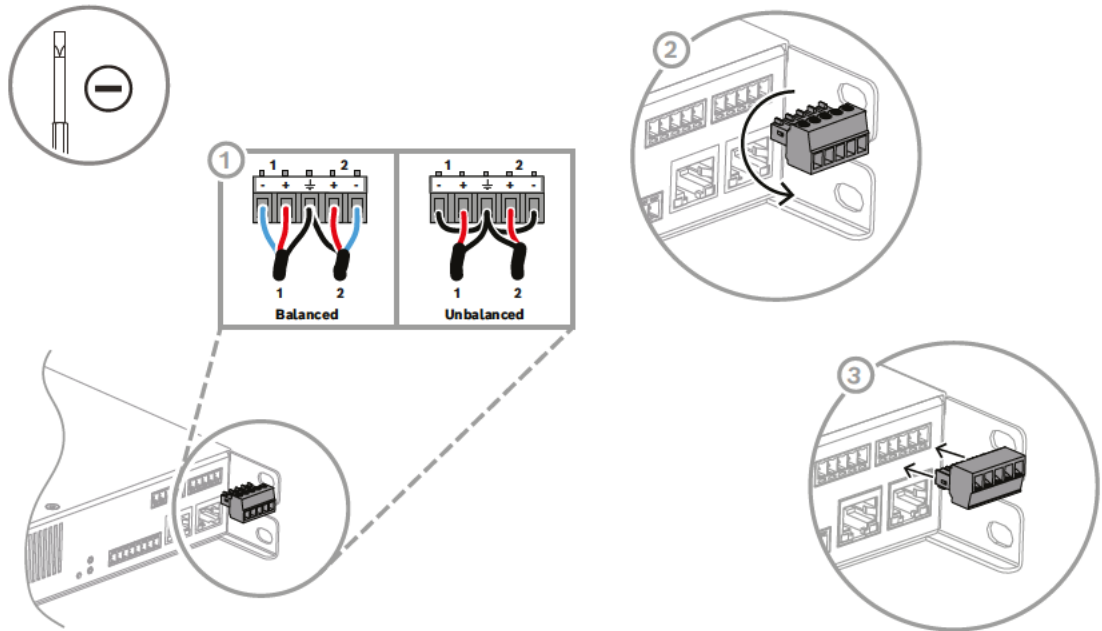

In addition to the analog mic/line inputs, IX series amplifiers can also receive their input signal from an OMNEO/Dante/AES67 network.

For more information on OMNEO/Dante/OCA network connection, refer to *OMNEO/Dante/OCA network connection*, page 25.

Input sources can be changed using SONICUE sound system software.

### Output connections (power outputs)

The output connectors are 8-pin Euroblock-type for IX60:8, IX30:8, IX30:4, IX15:4 and 4-pin Euroblock-type for IX60:4. This allows an easy prewiring of the cables outside the racks and a fast connection for multiple channels at once, without danger of wiring errors. Cabling requires class 2 wiring.

The operation modes (normal or bridge) can be set in SONICUE sound system software.

#### – Normal mode cabling

The speaker is connected to the respective + and - pole. The correct connection is also indicated at the amplifiers rear panel.

#### – Bridge mode cabling (not available for IX60:4)

In bridged mode both amplifier channels work in push-pull operation to provide doubled output voltage. The speaker connection has to be established using pins 1+/2-, 3+/4-, (5+/6- and 7+/8- for IX60:8 and IX30:8).

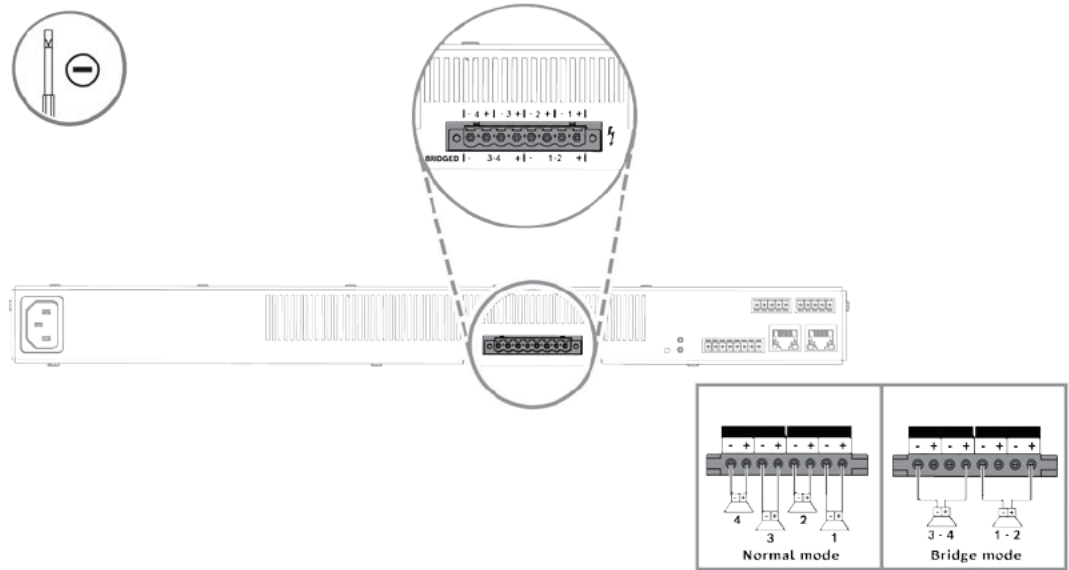

Figure 5.2: All models except IX60:4

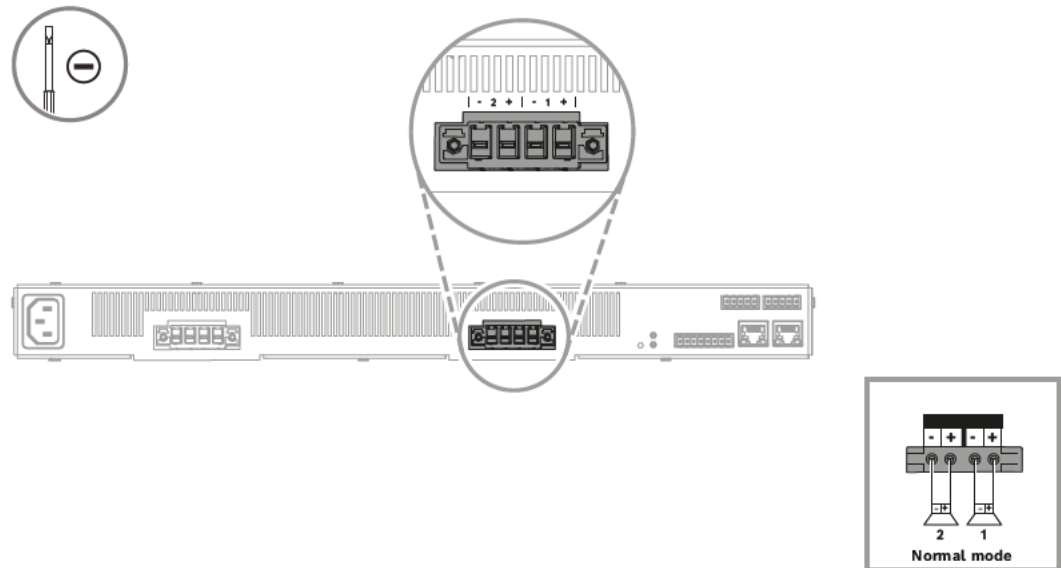

Figure 5.3: IX60:4



**Caution!**

In Bridge mode operation, it is not allowable to drive a total load below a value of 4 ohms. Extremely high voltages can be present at the output. The connected speaker systems must be able to handle such voltages. Make sure to completely read and fully observe power rating specifications of the speaker systems to be used and to check them against the output power capacity of the power amp. Property damage and/or personal injury may occur.

## 5.5

### OMNEO/Dante/OCA network connection

IX series amplifiers have two OMNEO/Dante/OCA network ports. They are labeled **PRIMARY (PoE)** and **SECONDARY**.

Configuration is done in SONICUE and allows selecting between the operation modes:

- Transparent
- RSTP
- Glitch-Free

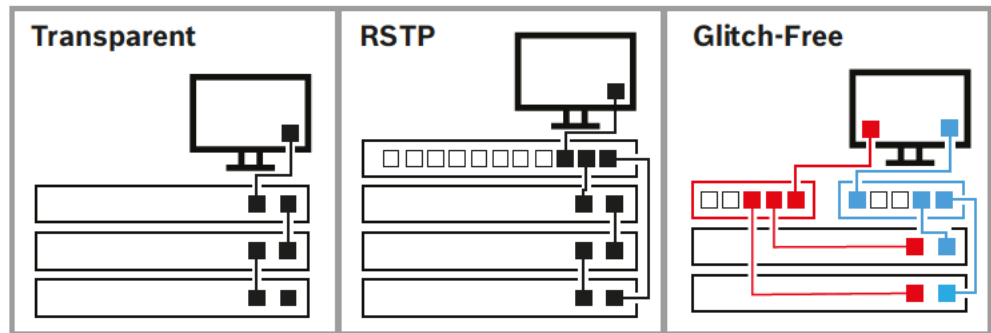
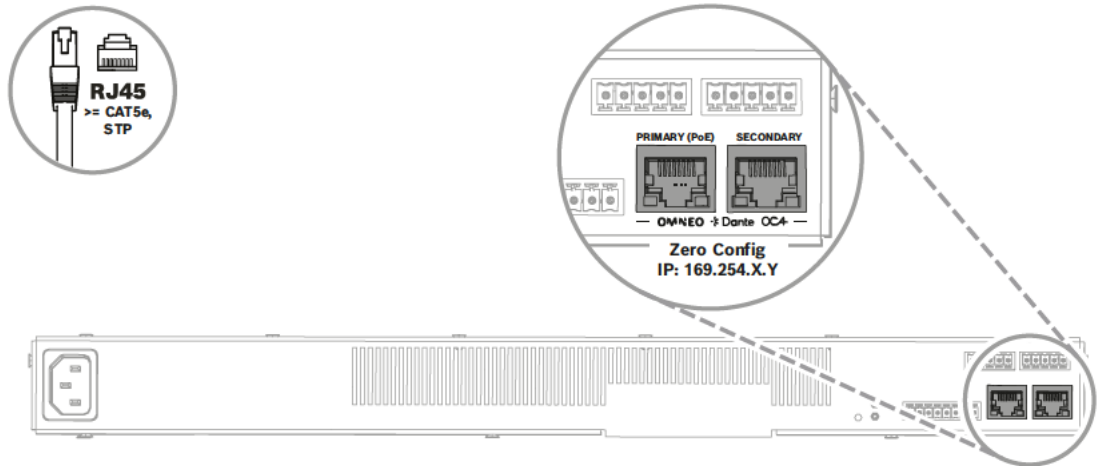

IX series amplifiers operate natively at 96 kHz sampling rate, Dante can be switched to either 48 kHz or 96 kHz. Factory default setting is 48 kHz.



**Notice!**

The OMNEO network comprises audio transport using the Dante protocol as well as OCA control commands. In order to guarantee the product performance according to specifications, network cabling has to be shielded, fulfilling the requirements of CAT 5e as a minimum. Factory default network setting is DHCP/AutoIP (zero config).

## 6 Configuration in SONICUE

The entire configuration and operation of IX series amplifiers is done via SONICUE Sound System Software.

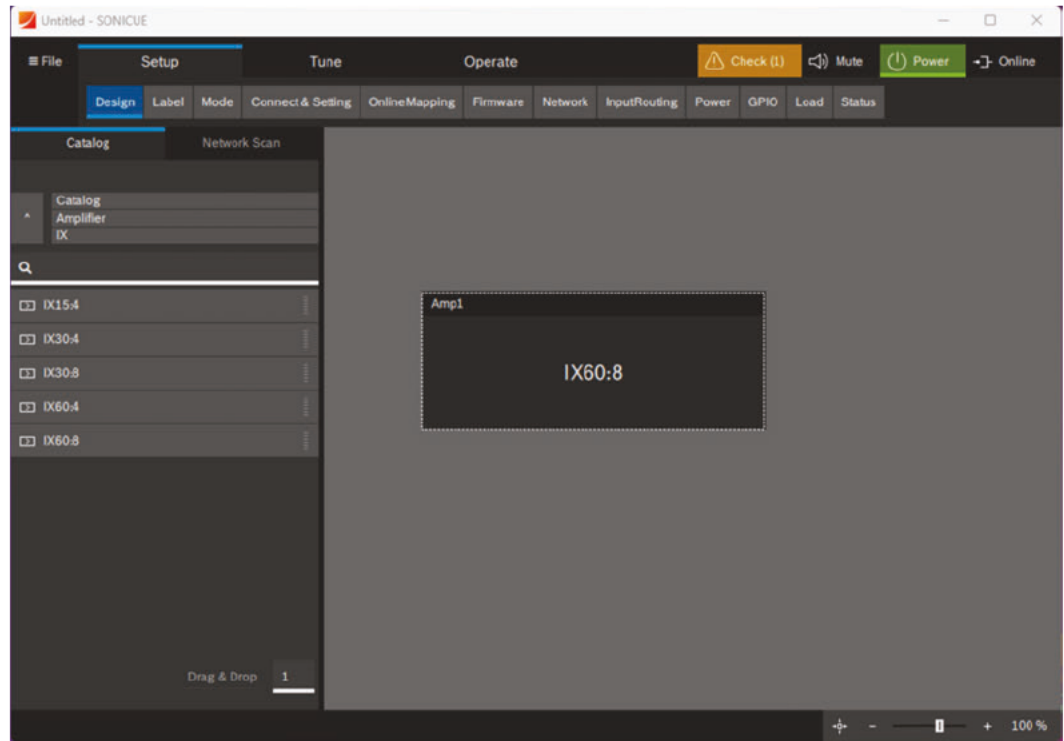

SONICUE is available as a free download at [www.kling-freitag.com](http://www.kling-freitag.com)

For information on the way of working of SONICUE, refer to the [online video tutorials](#).

### 6.1 Updating the firmware



#### Notice!

When the device is operated in Glitchfree mode, firmware update is only possible via **PRIMARY** port.

Each release of SONICUE Sound System Software includes a folder with matching firmware for all supported devices and a matching version of the OMNEO Firmware Upload Tool, which is required to update the firmware for most devices within the SONICUE eco system.

In addition, you can always find the latest firmware version for devices supported in SONICUE on the dedicated firmware download site, accessible straight from the SONICUE Settings Page.

To update firmware with the OMNEO Firmware Upload Tool:



#### Notice!

You need administrator rights on your PC to run the OMNEO Firmware Upload Tool. Mains power operation is mandatory for firmware updates. Use only a LAN connection, not WiFi.

1. Install the OMNEO Firmware Upload Tool that is part of the SONICUE release.  
Skip this step if you have the correct SONICUE version.
2. Execute the device firmware .msi, e.g., IX...msi.  
This will configure all files correctly and place them in the expected folders.

3. Connect the IX amplifier to your PC and start the OMNEO Firmware Upload Tool app. The tool will display the available devices. Ensure the network interface of your PC is set to **Obtain IP address automatic**. Ensure that the OMNEO Firmware Upload Tool is not set to **Secure** operation. The dedicated check box should be unchecked.

**Notice!**

It is possible to update multiple IX amplifiers connected in a network in parallel.

4. Select the device type, the individual devices and the firmware version you want to upload.
5. Click **Start**.  
The firmware update will start. Progress will display in the progress bar.
6. When the green bar is complete and the **State** shows **Finished**, all files were transferred successfully.  
Some firmware components might still get updated on the device. Keep mains power running.

**Notice!**

A firmware update will reset the configuration including TaskEngine of the IX amplifier. If you are updating amplifiers already in use, make sure to save a project file beforehand and go online “writing” after a firmware update.

## 6.2

### Web server

IX amplifiers have an integrated web server for diagnostics, network and service information.

To access the web browser:

- Go to <https://host name.local>.  
The host name, such as **IX-15A48C**, is available on the rear panel of the amplifier as well as in SONICUE.

Or

- Use the current IP address.

Once you access the web server:

- Page **Overview** will display.

The screenshot shows the web interface for a Dynacord IX-15e48c - IX30.4 amplifier. The left sidebar contains navigation links: Overview, Network, Logging, and Miscellaneous. The main content area displays the 'Device Statistics' page with the following data:

Device Statistics					
Power State	On	Mains	On	PoE	Off
Current	0.17 A	Voltage	229.95 V	Power Consumption	38.09 VA
Wallclock	22.5.2025, 10:32:58 GMT (UTC)	Firmware Version	0.45.57	Serial number	

The web server has four pages:

- **Overview**  
Provides the device statistics.

- **Network**

Allows you to set the IP address and time of the device, important for correct logging information.

The screenshot shows the configuration page for a Dynacord IX-15a48c - IX30:4 device. The left sidebar contains navigation options: Overview, Network (selected), Logging, and Miscellaneous. The main content area is divided into three sections:

- Network:** Contains fields for Mode (Transigent), IP Mode (DHCP), IP (10.30.201.28), Subnet Size (22), Gateway (10.30.200.1), and MAC (00:1c:44:15:a4:8c). An Apply button is located below these fields.
- Open Interface:** A toggle switch for Enabled, currently turned off.
- Time:** Shows the wallclock time as 22.5.2025, 10:33:36 GMT (UTC). A button labeled 'Set to Browser Time' is present. Below this, the Sync method is set to NTP via DHCP, and the NTP Servers field contains 10.35.29.237.

- **Logging**

Provides the current device log.

- **Miscellaneous**

Hosts the open source licenses.

### Rescue IP address - Link Local

You can use the IP address <https://169.254.1.0> as an alternative address to log to the webserver. If the device has been set to a fixed IP address that has been lost, you can use this IP address as a rescue access to change the IP address to the current subnet.

### Device reset

Resetting the device restores the amplifier to its factory settings and clears all memories, with the exception of the counter for operating hours.

To reset the amplifier to factory settings:

- Push the recessed **INIT** button with a small piston, such as an opened paper clip, and hold for minimum 30 seconds.  
If reset is successful, the status LED **INFO STATUS** will light up orange and the amplifier will reboot.

### 6.3 DSP and routing

The internal mix matrix combined with the 8 (4) analog microphone/line, 8 Dante audio inputs and also 8 assignable Dante outputs provide a lot of flexibility and use cases for IX series besides the application as standard networked amplifiers that use an input routed to one or several amplifier channels:

- Create a mix of local and network input sources and deploy them to the amplifier channels.
- Use local inputs as “break-in” to the Dante network (with or without channel processing).
- Send mixes of local and network sources to other network devices.

#### IX60:8 and IX30:8

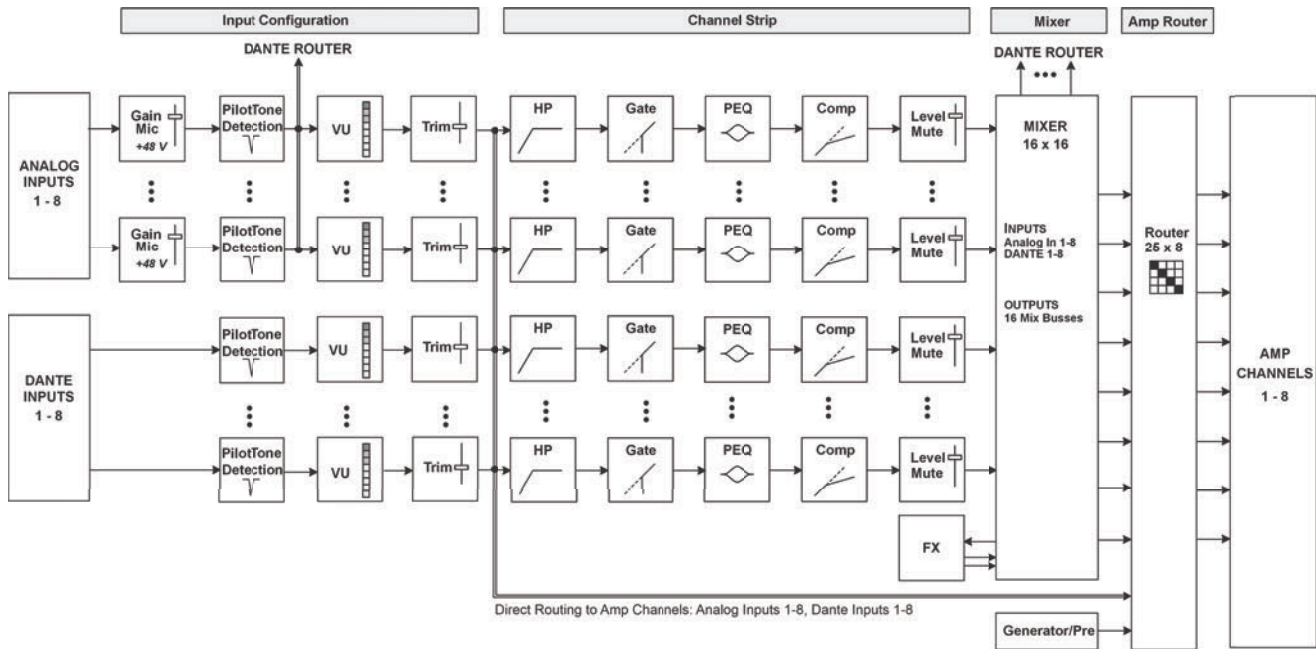

Figure 6.1: Block diagram for inputs

IX60:4 , IX30:4 and IX15:4

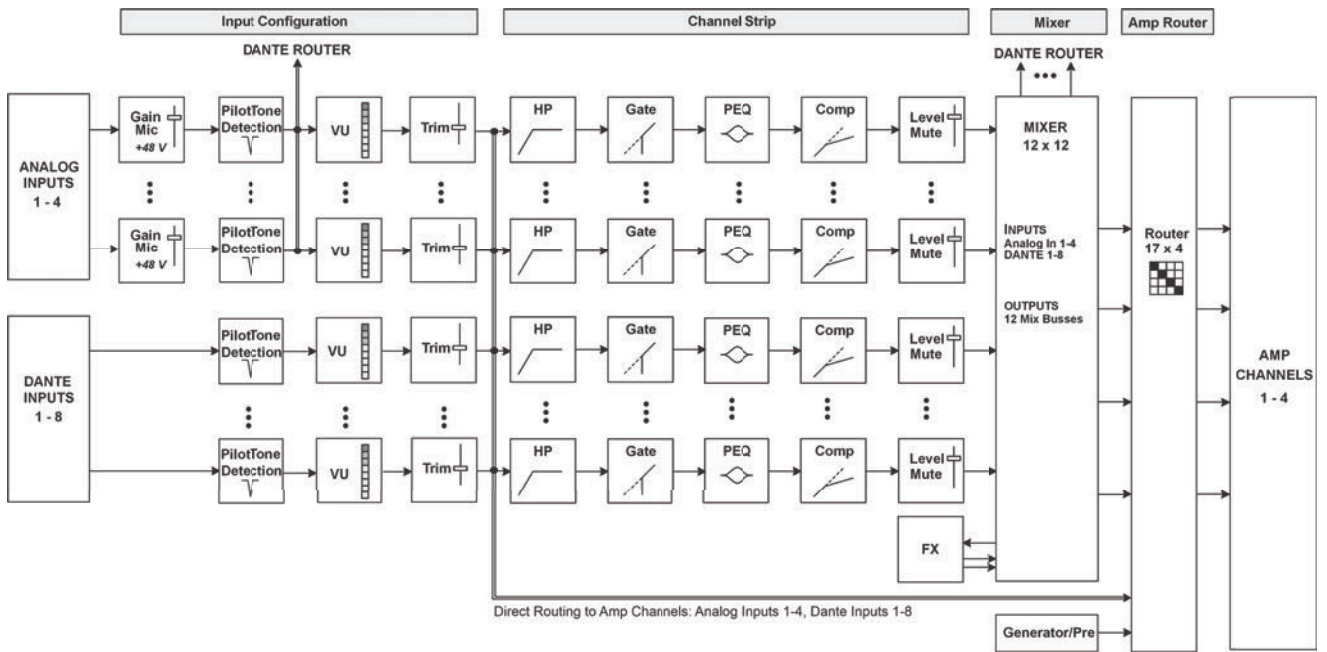

Figure 6.2: Block diagram for inputs

The input routing in SONICUE determines whether a source signal is routed directly to an amplifier channel, or if it is used with input processing in the 16 x 16 mixer (resp. 12 x 12 for the 4-channel amp versions). The mixer has 8 (4) mix busses that can be sent to the amplifier output channels and 8 (4) mix busses that can be sent to the Dante network.

IX60:8 and IX30:8

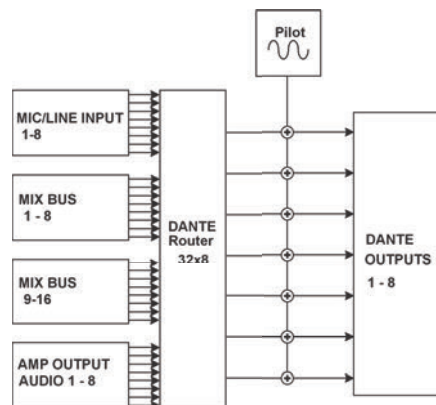

Figure 6.3: Dante router

IX60:4 , IX30:4 and IX15:4

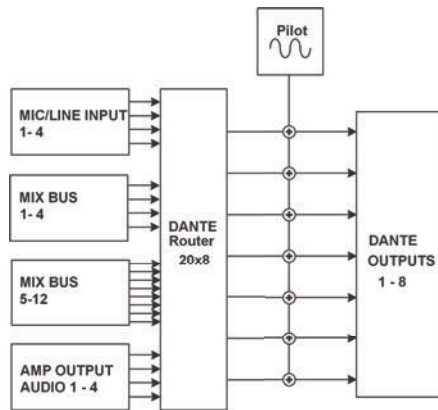

Figure 6.4: Dante router

Other signal options for sending to Dante are mic/line input post pre amp, and input signal post channel processing (EQ, dynamics). It is also possible to send the signal of an amplifier channel including the full channel processing.

The amplifier channels provide signal processing that are configurable in three blocks, similar to IPX series power amplifiers from Dynacord.

IX60:8 and IX30:8

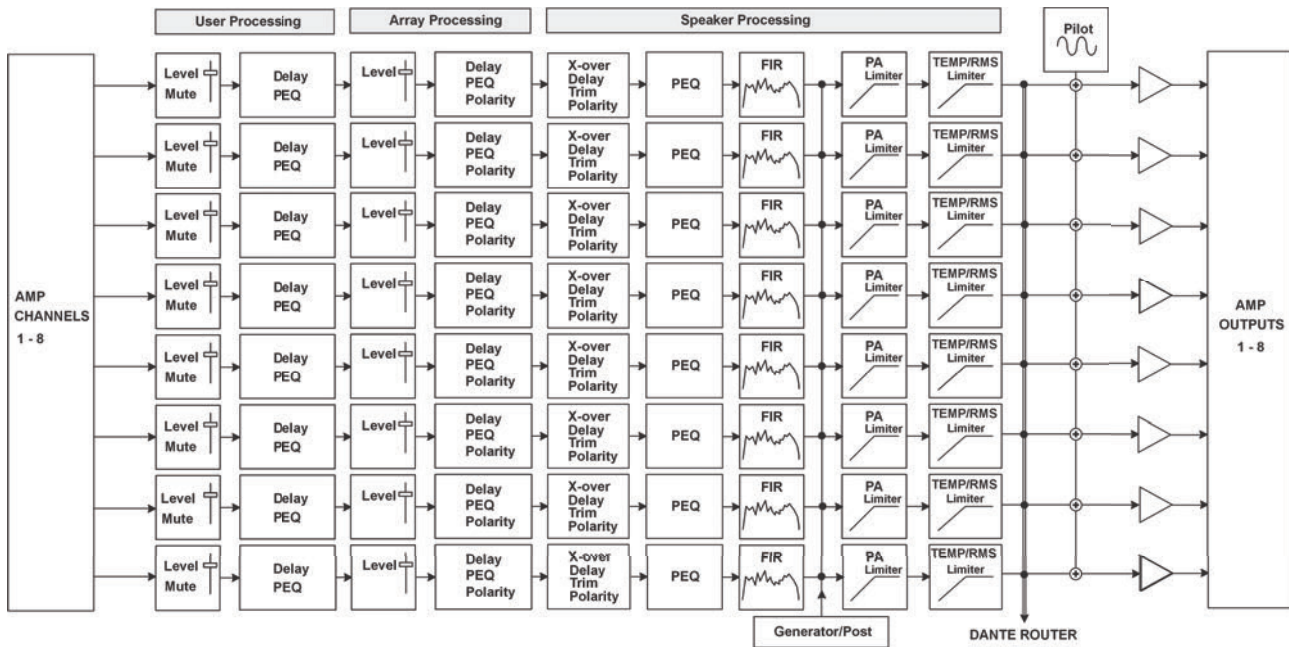

Figure 6.5: Block diagram for amplifier channels

IX60:4 , IX30:4 and IX15:4

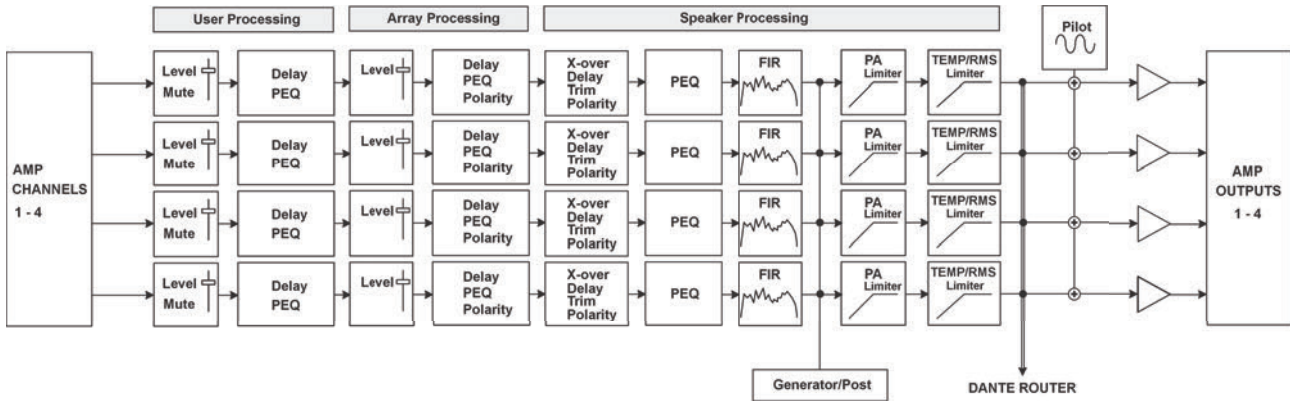

Figure 6.6: Block diagram for amplifier channels

User processing provides 12 configurable EQ bands, level, mute and up to 2000 ms delay time, array processing 5 EQs and up to 500 ms delay. Speaker processing can be used to load speaker settings from SONICUE’s speaker databases, or load custom speaker settings via the generic speaker.

## 6.4 TaskEngine

The TaskEngine allows to program logic tasks for the amplifier or other devices in the network. This option takes full advantage of the internal mixing capabilities of IX series and avoids the use of a “system matrix” when operating the amplifiers.

The TaskEngine derives from Dynacord’s MXE Matrix Mix Engine series and allows to:

- Control IX series and other system devices via SONICUE control panels or the WPN1 wall panel controller
- Create system scenes for manual or scheduled recall
- Manage sophisticated failover and override scenarios
- Integrate with or control third party devices via for example HTTP.

For more details, see the help in SONICUE.

## 7 Third party remote control

It is possible to integrate IX series amplifiers with third party AV control or building control systems. Dynacord provides plug-ins for common AV control systems with instructions. For more information, refer to Dynacord's download section "Third party plug-ins".

## 8 Technical data

### 8.1 Output power

OUTPUT POWER					
	IX60:8	IX30:8	IX60:4	IX30:4	IX15:4
Total rated output power <sup>1</sup>	6000 W	3000 W	6000 W	3000 W	1500 W
Number of amplifier channels	8		4		

#### IX60:8

Load	2 Ω	2.7 Ω	4 Ω	8 Ω
<b>Maximum Output Power<sup>1</sup></b>				
All channels equally driven	750 W	750 W	600 W	750 W
Max. per channel	1000 W	800 W	600 W	1000 W
Bridge	1000 W	1300 W	1500 W	1200 W

Direct Drive	70 V	100 V
<b>Maximum Output Power<sup>1</sup></b>		
All channels equally driven	750 W	750 W
Max. per channel	750 W	1000 W

#### IX30:8

Load	2 Ω	2.7 Ω	4 Ω	8 Ω
<b>Maximum Output Power<sup>1</sup></b>				
All channels equally driven	375 W	375 W	375 W	375 W
Max. per channel	1000 W	800 W	600 W	1000 W
Bridge	750 W	750 W	750 W	750 W

Direct Drive	70 V	100 V
<b>Maximum Output Power<sup>1</sup></b>		
All channels equally driven	375 W	375 W
Max. per channel	750 W	1000 W

**IX60:4**

Load	2 Ω	2.7 Ω	4 Ω	8 Ω
<b>Maximum Output Power<sup>1</sup></b>				
All channels equally driven	1000 W	1300 W	1500 W	1200 W
Max. per channel	1000 W	1300 W	1800 W	1200 W

Direct Drive	70 V	100 V
<b>Maximum Output Power<sup>1</sup></b>		
All channels equally driven	1500 W	1500 W
Max. per channel	1500 W	1800 W

**IX30:4**

Load	2 Ω	2.7 Ω	4 Ω	8 Ω
<b>Maximum Output Power<sup>1</sup></b>				
All channels equally driven	750 W	750 W	600 W	750 W
Max. per channel	1000 W	800 W	600 W	1000 W
Bridge	1000 W	1300 W	1500 W	1200 W

Direct Drive	70 V	100 V
<b>Maximum Output Power<sup>1</sup></b>		
All channels equally driven	750 W	750 W
Max. per channel	750 W	1000 W

**IX15:4**

Load	2 Ω	2.7 Ω	4 Ω	8 Ω
<b>Maximum Output Power<sup>1</sup></b>				
All channels equally driven	375 W	375 W	375 W	375 W
Max. per channel	1000 W	800 W	600 W	1000 W
Bridge	750 W	750 W	750 W	750 W

Direct Drive	70 V	100 V
<b>Maximum Output Power<sup>1</sup></b>		

Direct Drive	70 V	100 V
All channels equally driven	375 W	375 W
Max. per channel	750 W	1000 W

<sup>1</sup>Test signal for max. output power according IHFA-202 (Dynamic-Headroom, burst 1 kHz / 20 ms on / 480 ms off / low level -20 dB)

	IX60:8	IX30:8	IX60:4	IX30:4	IX15:4
Maximum Output Voltage, Hi-Z/4 -16 $\Omega$ mode, per channel <sup>2</sup>	145 V <sub>peak</sub>				
Maximum Output Current, Lo-Z/2 - 4 $\Omega$ mode, per channel <sup>2</sup>	33 A <sub>peak</sub>				

<sup>2</sup>No mode selection on IX60:4

## 8.2

### Amplifier

AMPLIFIER					
	IX60:8	IX30:8	IX60:4	IX30:4	IX15:4
Voltage Gain Low-Z mode, ref. 1 kHz	32 dB, adjustable 20.0 - 44.0 dB				
Input sensitivity Direct Drive mode	+6 dBu (1.55 V), fixed				
THD+N 3 dB below max, AES17, 1 kHz	< 0.1 %				
Crosstalk ref. 1 kHz, 12 dB below max, 8 $\Omega$	< -80 dB				
Frequency Response ref. 1 kHz, Analog In to Speaker Out	20 Hz to 20 kHz ( $\pm 1$ dB)				
Damping Factor 20 Hz to 200 Hz, 8 $\Omega$	> 250				
Output Stage Topology	Class D, fixed frequency				
Output Noise					
Analog input (A-weighted, eco mode)	< -67 dBu				
Digital input (A-weighted, eco mode)	< -70 dBu				
Mic/Line Analog Inputs					
Channels	8		4		

AMPLIFIER					
	IX60:8	IX30:8	IX60:4	IX30:4	IX15:4
Gain	0 to 60 dB				
Maximum Input Level (balanced)	+18 dBu				
Maximum Input Level (unbalanced)	+12 dBu				
Phantom power	+48 V, switchable per input				
Input Impedance, active balanced	>10 k $\Omega$				
EIN (A-weighted) @ 150 $\Omega$	-127 dBu				
Reference level equal to digital input	+22 dBu for 0 dBFS				

### 8.3 Digital signal processing

DIGITAL SIGNAL PROCESSING	
Sampling rate	96 kHz internal, Dante 48/96 kHz switchable
Signal delay/latency (Analog In to Speaker Out)	0.77 ms
<b>Signal Processing</b>	
Input processing	HPF 24 dB, 4 filters per channel, selectable as PEQ, Lo-/Hi-Shelv, Lo-/Hi-ShelvQ, Hi-/Lo-Pass and Notch; Noise Gate, Compressor or AGC; input pilot supervision
Mix Matrix	IX60:8 and IX30:8: 16 x 16 matrix mixer with stereo FX IX60:4, IX30:4 and IX15:4: 12 x 12 matrix mixer with stereo FX
User EQ	12 filters per channel, selectable as PEQ, Lo-Shelv, Hi-Shelv, Lo-ShelvQ, Hi-ShelvQ, Hi-Pass, Lo-Pass and Notch; 2 filters of them with additional asymmetric filter type
User Delay	0 to 2000 ms per channel
Array EQ	5 filters per channel, selectable as PEQ, Lo-Shelv, Hi-Shelv, Lo-ShelvQ, Hi-ShelvQ, Hi-Pass, Lo-Pass, and All-Pass
Array Delay	0 to 500 ms per channel
Speaker EQ	10 filters per channel, selectable as PEQ, Lo-Shelv, Hi-Shelv, Hi-Pass, Lo-Pass, and All-Pass
Speaker X-Over	Hi-Pass, and Lo-Pass per channel, 6/12/18/24/30/36/42/48 dB Bessel/Butterworth, 12/24/36/48 dB Linkwitz-Riley; Alignment Delay, 0 to 20 ms per channel
Speaker FIR	Up to 1025 taps

DIGITAL SIGNAL PROCESSING	
Speaker Limiters	Peak Anticipation Limiter and RMS/TEMP Limiter per channel
Load Supervision	Pilot tone up to 30 kHz
Other Functions	Source Selection, Level, Mute, Polarity, Sine and Noise Generator, Pilot Tone Generator and Detection, Level Meters, Impedance Measurement and Load Monitoring
DSP Presets	1 Factory + 20 User
Source Supervision and Fallback	Pilot Tone supervision at Analog and Dante inputs, switchover to FAILOVER source selection

## 8.4 Connectivity

CONNECTIVITY					
	IX60:8	IX30:8	IX60:4	IX30:4	IX15:4
<b>Mic/Line Input</b>					
Type (Euroblock)	4 x 5-pin, male		2 x 5-pin, male		
<b>Speaker Output</b>					
Type (Euroblock)	2 x 8-pin		2 x 4-pin	1 x 8-pin	
Diameter	2.5 mm <sup>2</sup> /12 AWG		6.0 mm <sup>2</sup> /10 AWG	2.5 mm <sup>2</sup> /12 AWG	
<b>Network</b>					
Type	2 x RJ45				
General	1000base-T/100base-TX, integrated switch				
Redundancy Modes	Glitchfree (PRIMARY/SECONDARY), RSTP				
Backup power supply (ghostPOWER)	1 x PoE (IEEE 802.3af) on PRIMARY port				
Network Audio Inputs	8 ch, 48/96 kHz, Dante				
Network Audio Outputs	8 ch, 48/96 kHz, Dante				
Mains Input	1 x IEC C14				
<b>Control Port</b>					
GPIO Control Port	3 x GPIO, switchable Analog In/Digital In/Digital Out				
Type	1 x 8-pin Euroblock, male				
Analog Input Range	0 V to +13 V, 133 k $\Omega$ input resistance				
Digital Input Limits	ON: < 1.5 V OFF: > 2.0 V, internal Pull Up (10 k $\Omega$ / 10 V)				

CONNECTIVITY					
	IX60:8	IX30:8	IX60:4	IX30:4	IX15:4
Digital Outputs	ON: Output switched to GND, max. 200 mA OFF: Open Collector				
Reference Voltage Output	+10 V, max. 200 mA, supervised, short circuit protected				
READY/FAULT	Galvanic isolated relay, max. 30 VDC/500 mADC				
Front panel indicators	6 x status LEDs (POWER, STANDBY, FAULT, OMNEO, PoE, AC), signal/peak LED per MIC/LINE input and AMPLIFIER output				
Rear panel indicators	2 x status LEDs (INFO, STATUS)				
Rear panel operation	1 x INIT button (recessed)				

## 8.5

### General

GENERAL					
	IX60:8	IX60:4	IX30:8	IX30:4	IX15:4
<b>Power consumption</b>					
Rated power consumption	1050 W		575 W	550 W	300 W
Idle/Eco mode (output power <1 W)	40 W	34 W	40 W	26 W	
Standby mode	<15 W				
Power Requirements	100 V to 240 V, 50 Hz to 60 Hz AC				
Power Supply Topology	Switching Mode Power Supply with digitally controlled power factor correction (PFC)				
Protections	Audio Limiters, High Temperature, DC, HF, Short Circuit, Back-EMF, Peak Current Limiters, Inrush Current Limiters, Mains Current Limiter, Mains Over-/Under Voltage Protection				
Cooling	Front-to-rear, temperature controlled fans, supervised				
Ambient Temperature Limits	+5 °C to +40 °C (+40 °F to +105 °F)				
IEC Protection Class	Class I (grounded)				
Electromagnetical Environment	E1, E2, E3				
Color	Black				
Dimensions (W x H x D)	483 mm x 44.1 mm x 447 mm (19 in x 1.74 in x 17 in)				
Weight	8.8 kg (19.3 lb)	8.6 kg (19 lb)	8.3 kg (18.2 lb)	7.5 kg (16.4 lb)	7 kg (15.4 lb)
Shipping weight	10.7 kg (23.4 lb)	10.5 kg (23.1 lb)	10.2 kg (22.5 lb)	9.3 kg (20.5 lb)	8.9 kg (19.5 lb)

Amplifier at rated conditions, Lo-Z/2 - 4  $\Omega$  normal operation mode, all channels driven, 4  $\Omega$  loads, analog input, 32 dB Gain, unless otherwise specified.



